

# Technical Manual

## **John Deere 450E Crawler Bulldozer 455E Crawler Loader Repair**

TM1330 (01OCT87)



Litho in U.S.A.



## **JOHN DEERE DEALERS**

**IMPORTANT: Please remove this page and route through your service department.**

This is a complete revision for TM-1330, 450E Crawler Bulldozer and 455E Crawler Loader.

Binder and tabs from old manual may be saved and used with this bound manual.

The new pages are dated (Oct-87). Listed below is a brief explanation of "WHAT" was changed and "WHY" it was changed.

This manual was revised:

1. To include the correct art and story for steering linkage.
2. To include story to apply a small amount of heat to backhoe cylinder nut to oxidize the thread lock and sealer (medium strength).

T64;1330 DCSR 211087



**Thanks very much for your reading,  
Want to get more information,  
Please click here, Then get the complete  
manual**

**JustClickHere** 

**NOTE:**

**If there is no response to click on the link above,  
please download the PDF document first, and then  
click on it.**

**Have any questions please write to me:  
[admin@servicemanualperfect.com](mailto:admin@servicemanualperfect.com)**

# 450E CRAWLER BULLDOZER AND 455E CRAWLER LOADER TECHNICAL MANUAL TM-1330 (Oct-87)

## SECTION AND GROUP CONTENTS

### SECTION I - GENERAL INFORMATION

- Group I - Introduction and Safety Information
- Group II - General Specifications
- Group III - Torque Specifications Chart  
for Cap Screws and Hydraulic Fittings
- Group IV - Lubrication

### SECTION 01 - TRACKS

- Group 0130 - Track Systems
  - Track Chain, Track Frame, Track Carrier
  - Roller, Front Idler, Track Roller and Track Adjuster

### SECTION 02 - AXLES AND SUSPENSION SYSTEMS

- Group 0250 - Axle Shaft, Bearings, Reduction Gears
  - Final Drive, Steering Clutch, Brake Band, Steering Clutch Housing and Linkage

### SECTION 03 - TRANSMISSION

- Group 0315 - Controls
- Group 0350 - Gears, Shafts, Bearings, and H-L-R Clutch
  - Clutch Oil Pump, H-L-R Clutches, Control Valve, Clutch Accumulator Valve, Clutch Oil Manifold, Shift Valve, Transmission Oil Filter, Shift Linkage, Neutral Start Switch and Transmission Oil Cooler
- Group 0360 - Transmission Hydraulics (See Group 0350)

### SECTION 04 - ENGINE—Continued

- Group 0400 - Removal and Installation
- Group 0401 - Crankshaft and Main Bearings
- Group 0402 - Camshaft and Valve Actuating Means
- Group 0403 - Connecting Rods and Pistons
- Group 0404 - Cylinder Block (Liners)
- Group 0407 - Engine Oiling System
- Group 0409 - Cylinder Head and Valves
- Group 0410 - Exhaust Manifold
- Group 0413 - Fuel Injection System
- Group 0414 - Intake Manifold
- Group 0415 - Engine Balancer
- Group 0416 - Turbocharger
- Group 0417 - Water Pump
- Group 0418 - Thermostats, Housing and Piping
- Group 0419 - Engine Oil Cooler
- Group 0420 - Fuel Filter
- Group 0421 - Fuel Transfer Pump
- Group 0422 - Starting System
- Group 0433 - Flywheel, Housing and Fasteners

### SECTION 05 - ENGINE AUXILIARY SYSTEMS

- Group 0505 - Cold Weather Starting Aids
- Group 0510 - Cooling Systems
- Group 0515 - Speed Controls
- Group 0560 - External Fuel Supply Systems

### SECTION 7 - CLUTCH

- Group 0715 - Controls
- Group 0752 - Elements

*Continued on next page*

*All information, illustrations and specifications contained in this technical manual are based on the latest information available at the time of publication. The right is reserved to make changes at any time without notice.*

Copyright© 1987  
DEERE & COMPANY  
Moline, Illinois  
All Rights Reserved  
A JOHN DEERE ILLUSTRATION  
Previous Edition  
Copyright© 1986 Deere & Company  
Copyright© 1985 Deere & Company

T64:1330 13 240987

## SECTION AND GROUP CONTENTS—Continued

### SECTION 09 - STEERING SYSTEMS

Group 0960 - Power Steering

### SECTION 15 - EQUIPMENT ATTACHING

Group 1511 - Drawbar

### SECTION 16 - ELECTRICAL SYSTEM

Group 1671 - Batteries, Support, and Cables

Group 1672 - Alternator

Group 1674 - Wiring Harness and Switches

Group 1676 - Instruments and Indicators

### SECTION 17 - FRAME, CHASSIS, OR SUPPORTING STRUCTURE

Group 1740 - Frame Installation

Group 1746 - Frame Bottom Guards

Group 1749 - Chassis Weights

Sprocket, Rear, and Bottom Counterweights

### SECTION 18 - OPERATOR'S STATION

Group 1810 - Operator Enclosure

ROPS, Cab, Windshield Wiper Motor,

Operator Seat, and Backhoe Seat

### SECTION 19 - SHEET METAL

Group 1910 - Hood or Engine Enclosure

Grille and Grille Housing, Cowl and Cowl Support

### SECTION 30 - WINCH

Group 3015 - Controls Linkage

Group 3050 - Winch Drive and Clutches

Group 3060 - Winch Hydraulic System

Winch Control Valve and Hydraulic Pump

### SECTION 31 - LOADER

Group 3102 - Buckets

Group 3103 - Forks

Group 3115 - Controls Linkage

Group 3140 - Frames

Group 3160 - Hydraulic System

Loader Cylinders, Hydraulic Pump and

Loader Control Valve

### SECTION 32 - BULLDOZER

Group 3201 - Blades

Group 3215 - Controls Linkage

Group 3240 - Frames

Group 3260 - Hydraulic System

Hydraulic Return Filter, Reservoir, Pump,

Pump Drive, Dozer Control Valve, Auxiliary

Valve, Selector Valve, Flow Divider and

Bulldozer Cylinders

### SECTION 33A - BACKHOE - 9300

Group 3300A - Removal and Installation

Group 3302A - Bucket

Group 3315A - Controls Linkage

Group 3340A - Frames

Group 3360A - Hydraulic System

Control Valve, Lift Check, Anti-Cavitation

Valve, Relief Valve, Manifold Block and

Backhoe Cylinders

### SECTION 33B - BACKHOE - 9550

Group 3300B - Removal and Installation

Group 3302B - Bucket

Group 3315B - Controls Linkage

Group 3340B - Frames

Group 3360B - Hydraulic System

Control Valve, Lift Check, Anti-cavitation

Valve, Relief Valve, Manifold Block and

Backhoe Cylinders

### SECTION 37 - LOG ARCH

Group 3740 - Arch Frames

### SECTION 40 - WINCH DRIVE

Group 4051 - Gears, Shafts and Bearings

### SECTION 42 - GROUND CONDITIONING TOOL

Group 4201 - Teeth and Shanks

Group 4240 - Frame

Group 4260 - Hydraulic System

### SECTION 99 - DEALER FABRICATED TOOLS

T64;1330 14 211087

## INTRODUCTION

This technical manual is part of a twin concept of service.

### FOS Manuals - for reference

### Technical Manuals - for machine service

The two kinds of manuals work as a team to give you both the general background and technical details of shop service.

*Fundamentals of Service (FOS) Manuals* cover basic theory of operation, fundamentals of troubleshooting, general maintenance, and basic types of failures and their causes. FOS Manuals are for training new personnel and for reference by experienced technicians.

*Technical Manuals* are concise service guides for specific machines. Technical manuals are on-the-job guides containing only the vital information needed by an experienced service technician.

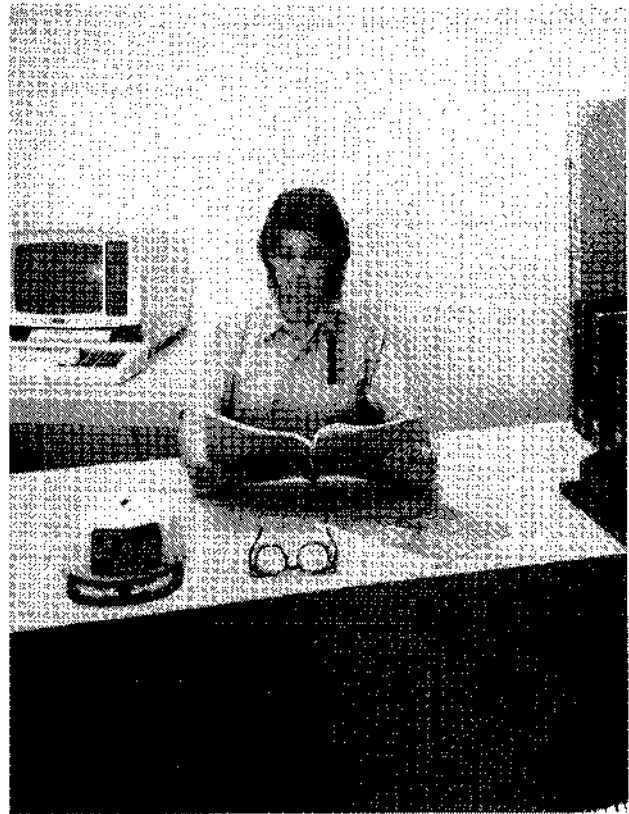

018;T58848B T82;FLPD G 310785

## FEATURES OF THIS TECHNICAL MANUAL

John Deere ILLUSTRATION format emphasizing illustrations and concise instructions in easy-to-use modules.

Emphasis on diagnosis, analysis, and testing so you can understand the problem and correct it.

Diagnostic information presented with the most logical and easiest to isolate problems first to help you identify the majority of routine failures quickly.

Step-by-step instructions for teardown and assembly.

Summary listing at the beginning of each group of all applicable specifications, wear tolerances, torque values, essential tools, and materials needed to do the job.

An emphasis throughout on safety—so you do the job right without getting hurt.

This technical manual was planned and written for you - an experienced service technician. Keep it in a permanent binder in the shop where it is handy. Refer to it when you need to know correct service procedures or specifications.



018;T58848C T82;FLPD H 310785



## USING TABS

To fully utilize this technical manual, you must understand how it is organized.

Only two tab colors are used—gray and yellow. Each color represents a different type of information.

Spend a minute reading this now and save many minutes of searching later.

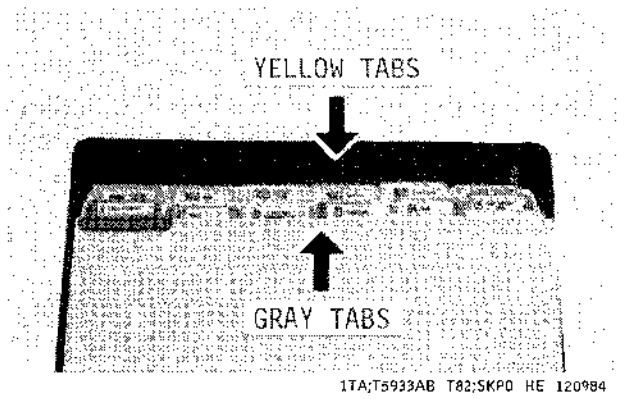

1TA;T5933AB T82;SKPO HE 120984

## GRAY TAB SECTIONS

The gray tab sections are repair sections that tell how to repair the components of the various systems.

Repair of a component includes:

- Removal from machine (when necessary)
- Disassembly
- Inspection
- Replacement of parts
- Assembly
- Adjustment
- Installation on machine (when necessary)

The numbers used for the repair (gray tab) sections are part of an overall service publication numbering system. The numbers identify the same sections in the parts catalog, flat rate manual, service information bulletins, and service training courses.

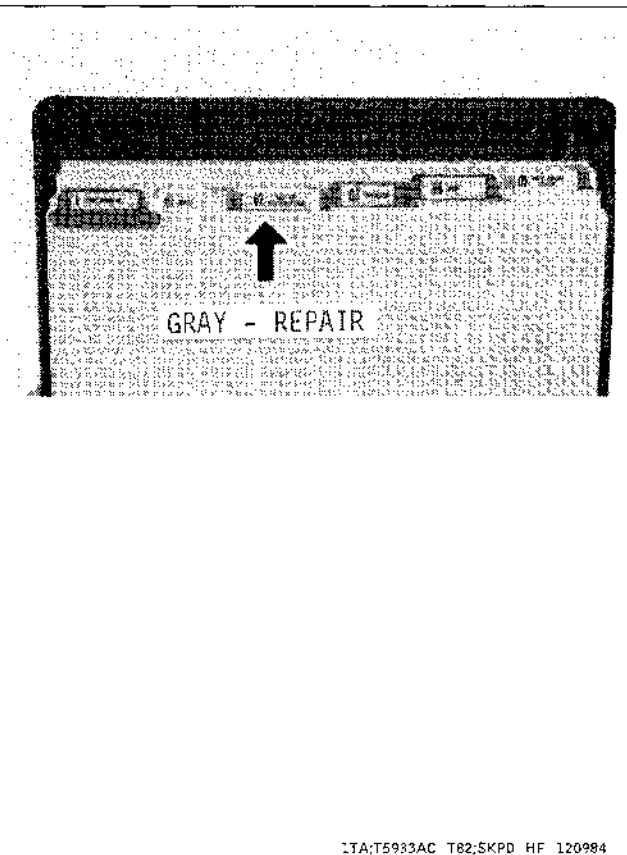

1TA;T5933AC T82;SKPD HF 120984

## YELLOW TAB SECTIONS

Each yellow tab section contains information on:

Groups	
05	Theory of Operation
10	System Operational Checks
15	Diagnostic Information
20	Adjustments
25	Tests

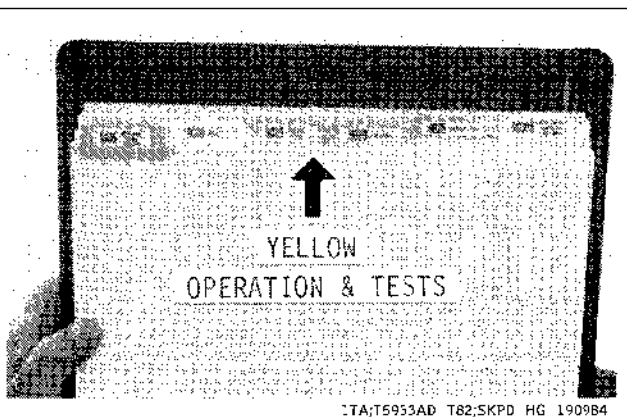

1TA;T5933AD T82;SKPD HG 120984

### THREE-STEP PROCEDURE

Use the following three-step procedure to locate the desired information.

1. Determine the type of information you need. Is it repair, operation, or tests?
2. Go to the appropriate section tab:  
Gray for Repair  
Yellow for Operation or Tests

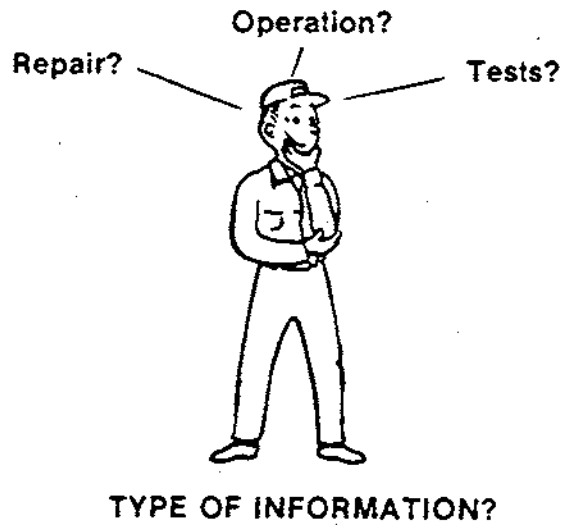

1TA;T5940AT T82;SKPD HI 120984

3. Use the table of contents on the first page of the section to locate the information.

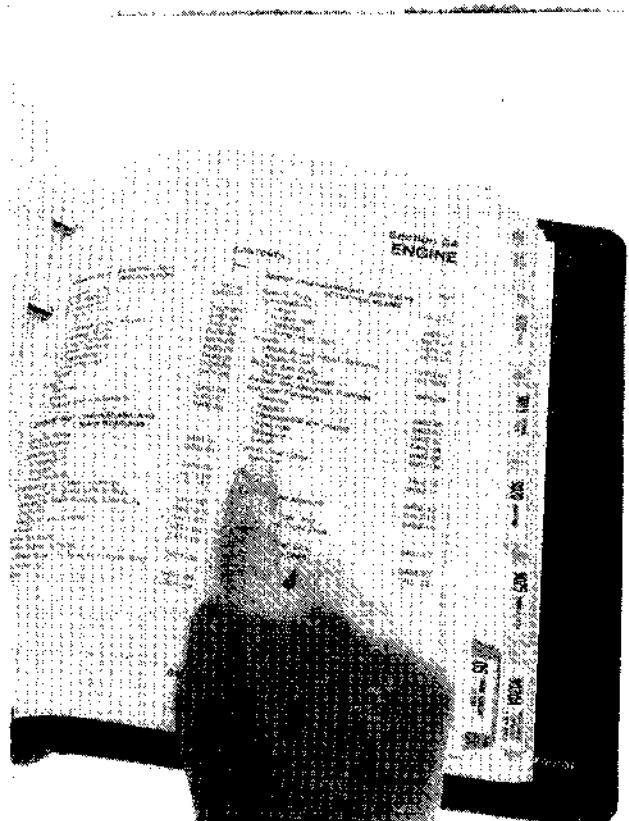

1TA;T5933AF T82;SKPD HJ 140984

**SAFETY AND YOU**

This safety-alert symbol means ATTENTION! BECOME ALERT! YOUR SAFETY IS INVOLVED!

When you see this symbol on your machine or in your manual, be alert to the possibility of personal injury. Follow the instructions in the safety message.



018:781389 T82:FLPD N 061186

## **AVOID FIRE HAZARDS**

Be prepared if an accident or fire should occur. Know where the first aid kit and the fire extinguishers are located — know how to use them.

Do not smoke while refueling or handling highly flammable material.

Shut off the engine when refueling.

Use care in refueling if the engine is hot.

Do not use open pans of gasoline or diesel fuel for cleaning parts. Use good commercial, nonflammable solvents.

Provide adequate ventilation when charging batteries.

Do not check battery charge by placing metal objects across the posts.

Do not allow sparks or open flame near batteries.

Do not smoke near battery.

Never check fuel, battery electrolyte, or coolant levels with an open flame.

Never use an open flame to look for leaks anywhere on the equipment.

Never use an open flame as light anywhere on or around the equipment.

When preparing engine for storage, remember that inhibitor is volatile and therefore dangerous. Seal and tape openings after adding the inhibitor. Keep container tightly closed when not in use.

Inspect electrical wiring for worn or frayed insulation. Install new wiring if wires are damaged.



## AVOID TIPPING

When you operate on a slope, do not swing the bucket down-hill if possible.

When you swing heavy loads to the side of the tracks, avoid tipping the excavator.

When the bucket is loaded, be careful when you swing or lift the boom.

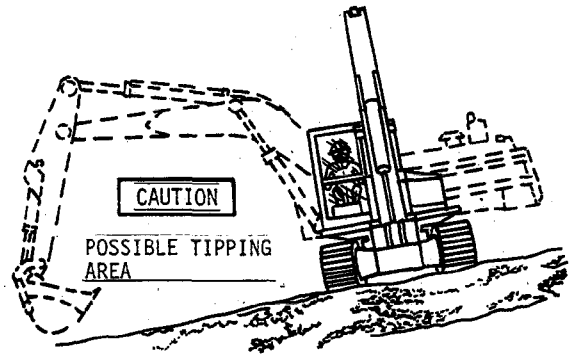

44A;182326 T82;EXSA G 030282

## WEAR PROTECTIVE CLOTHING

Wear fairly tight clothing . . . and safety equipment.



44A;T85056 T82;EXSA B 060684

## PROTECT AGAINST NOISE

Prolonged exposure to loud noise can cause impairment or loss of hearing. Wear a suitable hearing protective device such as earmuffs (A) or earplugs (B) to protect against objectionable or uncomfortable loud noise.



88A;X7662 T82;BHS A E 070684

## AVOID HIGH-PRESSURE FLUIDS

Escaping fluid under pressure can penetrate the skin causing serious injury. Relieve pressure before disconnecting hydraulic or other lines. Tighten all connections before applying pressure. Keep hands and body away from pinholes and nozzles which eject fluids under high pressure. Use a piece of cardboard or paper to search for leaks.

If ANY fluid is injected into the skin, it must be surgically removed within a few hours by a doctor familiar with this type injury or gangrene may result.

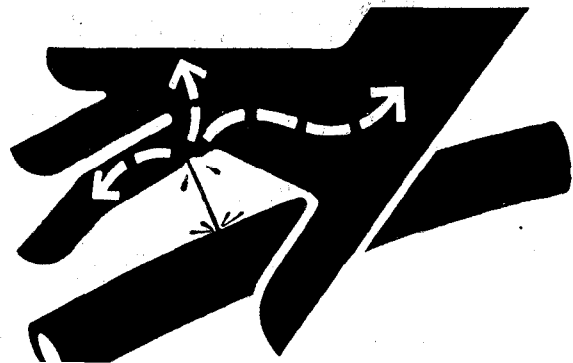

44A;X9811 T82;BHS A F 140984

## PREVENT MACHINE RUNAWAY

Avoid possible injury or death from machine runaway.

Do not start engine by shorting across starter terminals. Machine will start in gear and will move if normal circuitry is bypassed.

NEVER start engine while standing on ground. Start engine only from operator's seat, with gear shift lever in neutral position, HLR lever in neutral position and locked, and brake lock lever engaged.

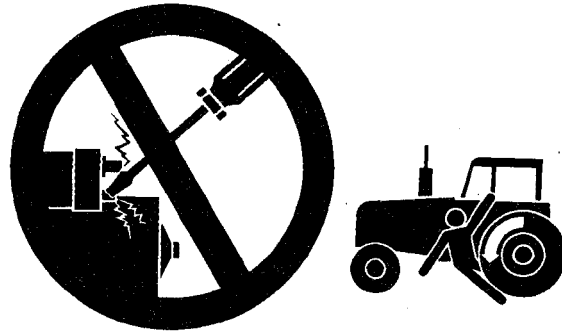

AB6;TS177 T82;CRSA AI 201284

## USE A SAFETY CHAIN

A safety chain will help control drawn equipment should it accidentally separate from the drawbar.

Using the appropriate adapter parts, attach the chain to the tractor drawbar support or other specified anchor location. Provide only enough slack in the chain to permit turning.

See your John Deere dealer for a chain with a strength rating equal to or greater than the gross weight of the towed machine. Do not use safety chain for towing.

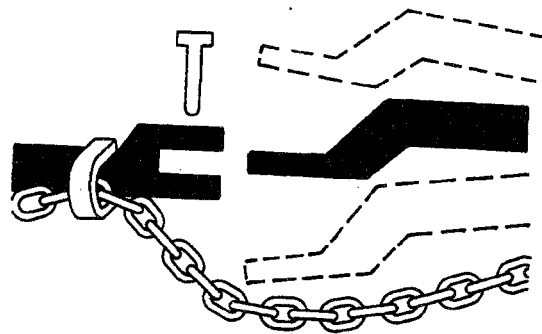

AB6;TS208 053;CHAIN 180987

## USE SEAT BELT PROPERLY

Use a seat belt when you operate with a roll-over protective structure (ROPS) to minimize chance of injury from an accident such as an overturn.

Do not use a seat belt if operating without a ROPS.

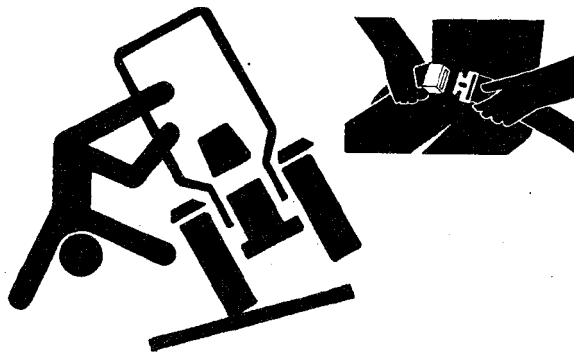

AB6;TS205 053;ROPS1 230487

## KEEP RIDERS OFF MACHINE

Only allow the operator on the machine. Keep riders off.

Riders on machine are subject to injury such as being struck by foreign objects and being thrown off of the machine. Riders also obstruct the operator's view resulting in the machine being operated in an unsafe manner.

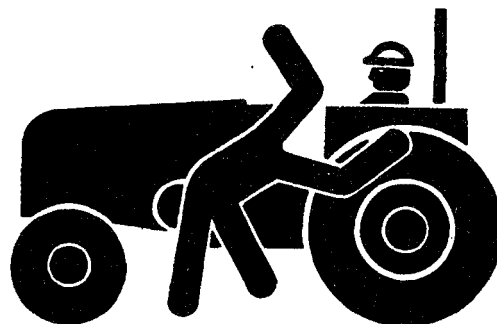

AB6;TS213 053;RIDER 160687

### HANDLE STARTING FLUID SAFELY

If your machine is equipped with a starting fluid starting aid, remember starting fluid is highly flammable. DO NOT incinerate or puncture a starting fluid container. DO NOT store a starting fluid container in a high-temperature area.



44A;T90207 182;CRSA G 070684

### PROTECT AGAINST FLYING DEBRIS

When you drive connecting pins in or out, guard against injury from flying pieces of metal or debris. Wear goggles or safety glasses and hard hat.

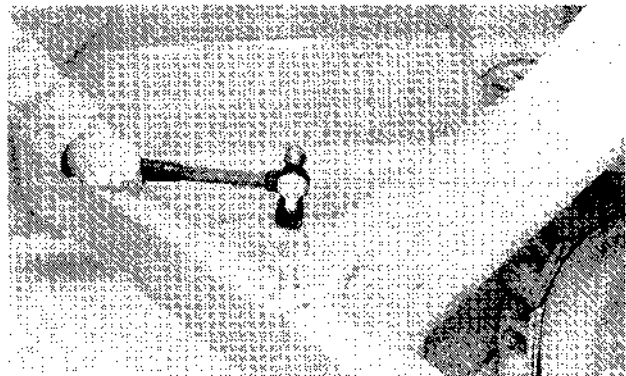

86A;T90211 T82;CRSA K 040984

### SUPPORT RAISED EQUIPMENT

Do not work under raised equipment unless it has a support under it.

On crawler loaders, use the boom safety lock bar (A) stored in the battery compartment.

If a support is not available, lower equipment to the ground.

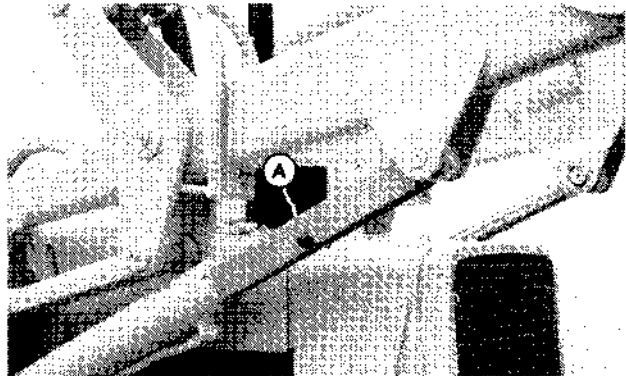

86A;T91444 82;CRSA AQ 051284

### KEEP ROPS INSTALLED PROPERLY

Make certain all parts are reinstalled correctly if the roll-over protective structure (ROPS) is loosened or removed for any reason. Tighten mounting bolts to proper torque.

The protection offered by ROPS will be impaired if ROPS is subjected to structural damage, is involved in an overturn incident, or is in any way altered by welding, bending, drilling, or cutting. A damaged ROPS should be replaced, not reused.

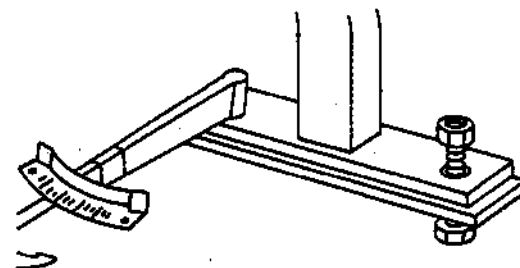

A66;TS212 053;R0P53 230487

**CAUTION:** Do not plug coolant heater into electrical power unless heating element is immersed in coolant. Sheath could burst and result in personal injury.

Use a heavy-duty grounded cord to connect coolant heater to electrical power.

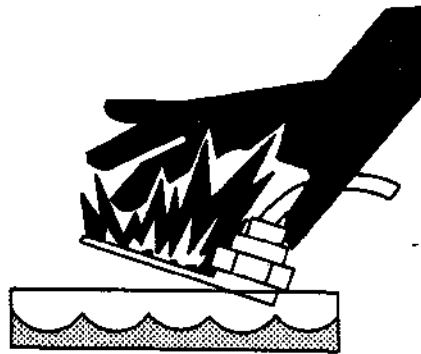

AB6;TS210 02T;05 K53 221087

### CLEAN THE MACHINE REGULARLY

Remove any grease, oil or debris build-up to avoid possible injury or machine damage.

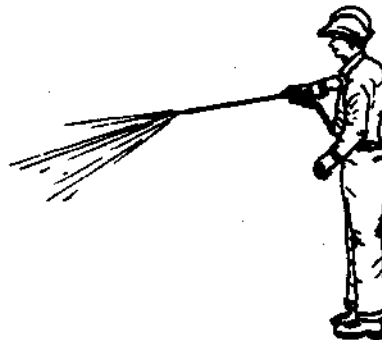

000;T5B13AM T82;CRSA AH 051284

### PREPARE MACHINE FOR REPAIR

1. Lower all equipment to the ground.
2. Move HLR lever to neutral "N" position.
3. Turn HLR neutral-lock lever to lock position.
4. Move gear shift lever to the neutral "N" position.
5. Apply and lock foot brake.
6. Stop the engine.
7. Operate all hydraulic control levers to release hydraulic pressure in the system.
8. Disconnect negative (-) battery cable.



88A;T5933AM T82;CRSA AZ 080185



*Introduction and Safety*

# Group II Specifications

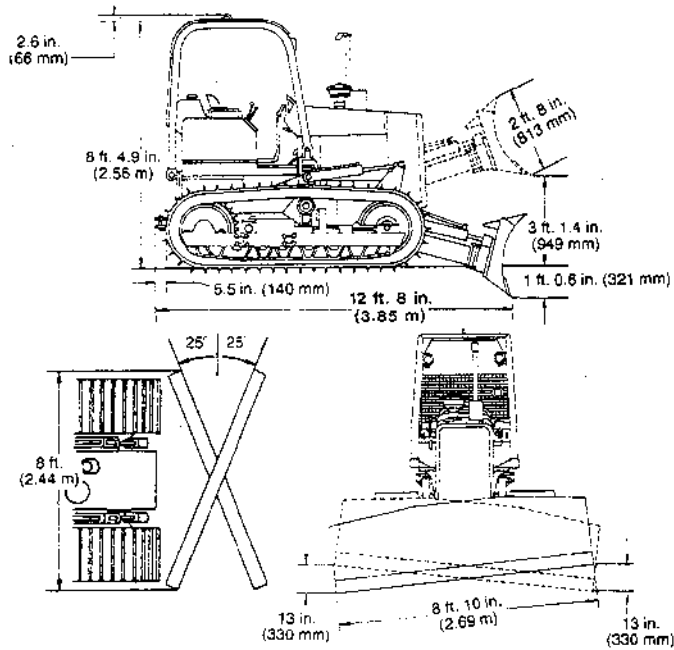

**450E Crawler Tractor With 6405 Blade**

000;T6020AM T82;CRSP S 030185

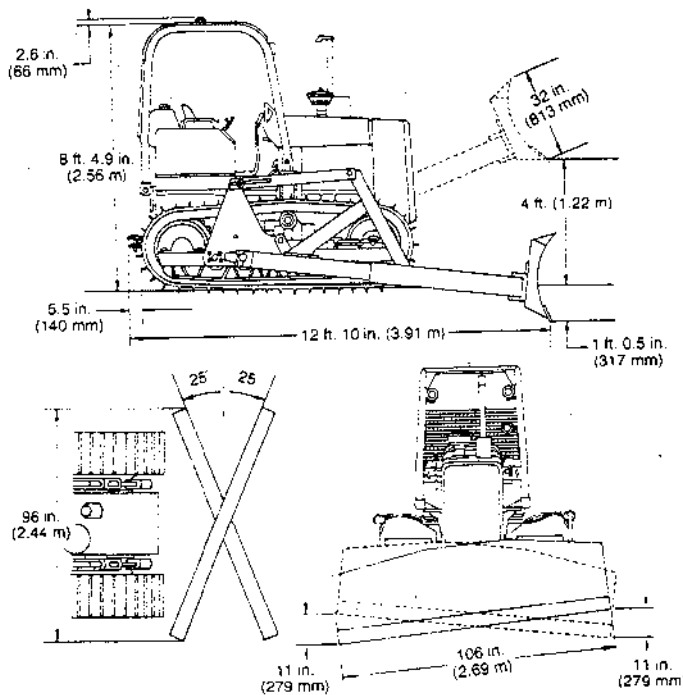

**450E Crawler Tractor With 6410 Blade**

000;T6020AM T82;CRSP T 030185

## Specifications

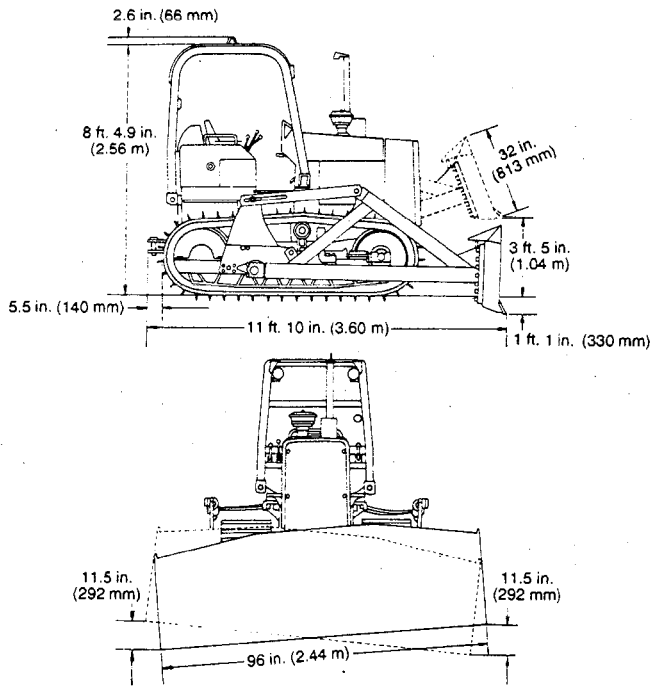

**450E Crawler Tractor With 6415 Blade**

000;T6020AP T82;CRSP U 030185

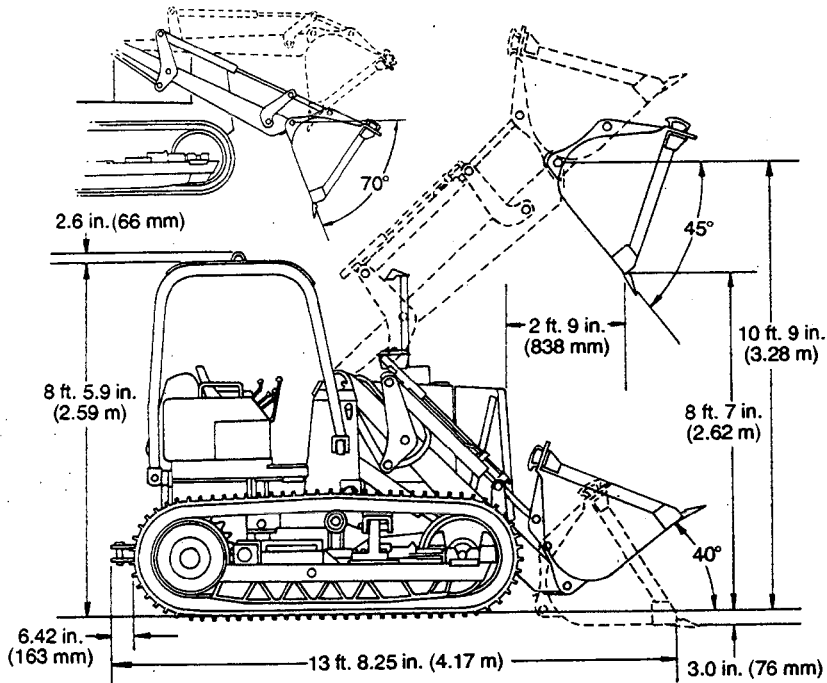

**455E Crawler Loader**

88A;T92254 T82;CRSP X 111284

## Specifications

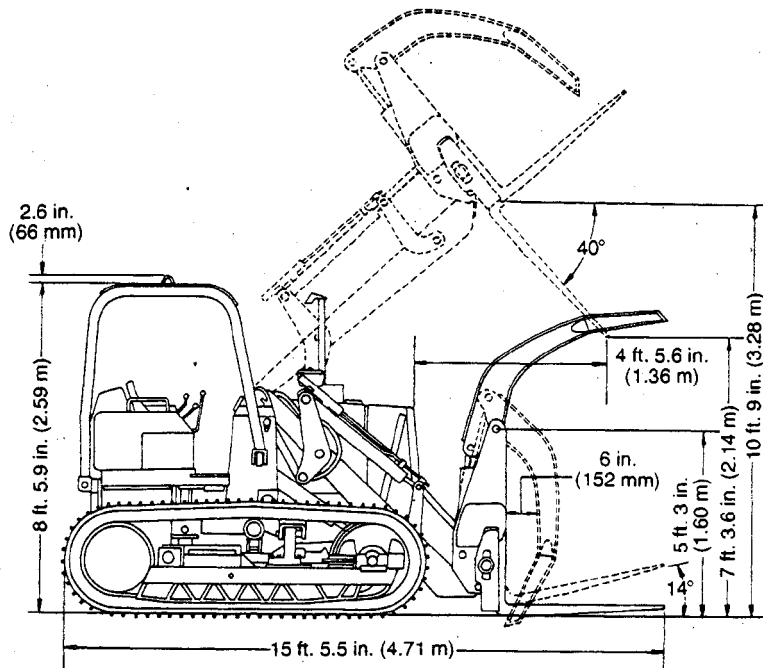

**455E Log and Lumber Loader**

88A/T5936AB T82;CRSP Y 111284

### GENERAL SPECIFICATIONS

#### Engine:

John Deere 4-cylinder turbocharged diesel  
 SAE net horsepower ..... 70 hp (52 kw)  
 Piston displacement ..... 276 cu. in. (4.524 L)  
 Fan ..... Blower  
 Electrical system ..... 12 volt with alternator  
 Battery (12 volt) . Reserve capacity: 180 minutes

#### Steering:

Clutches ..... Oil-cooled, hydraulically activated,  
 multiple disk, 11 in. (279 mm)  
 disks; 16 friction surfaces per  
 clutch.

#### Hydraulic Cylinders

(450E):	Bore	Stroke
Lift (2) .....	3.5 in. (89 mm)	15 in. (381 mm)
Angle (2) .....	3.5 in. (89 mm)	13.375 in. (343 mm)
Tilt (1) (6405) ..	3.5 in. (89 mm)	3 in. (76 mm)
Tilt (1) (6415) ..	4.5 in. (114 mm)	3 in. (76 mm)
(455E):	Bore	Stroke
Boom (2) ..	4.25 in. (108 mm)	28.25 in. (718 mm)
Bucket (2) .....	3.5 in. (89 mm)	31.1 in. (790 mm)

#### Hydraulic System:

Pressure .....	2250 psi (15 514 kPa)
Pump flow at 2000 rpm (450E):	
Large pump ... New—	18.1 gpm (68.4 L/min)
Used—	15.3 gpm (57.7 L/min)
Small pump .... New—	14.2 gpm (53.7 L/min)
Used—	11.2 gpm (42.3 L/min)
Long Track .... New—	12.0 gpm (45.4 L/min)
Used—	9.4 gpm (35.7 L/min)
Pump flow at 2000 rpm (455E):	
Pump .....	New—23.3 gpm (88.3 L/min)
Used—	19.7 gpm (74.6 L/min)

#### Undercarriage:

Track shoes, each side:	
450E .....	36
450ELT .....	39
455E .....	37
Track gauge .....	52 in. (1.27 m)
450ELT .....	54 in. (1.37 m)
450ELT Wide Track .....	60 in. (1.52 m)
Clearance at rear crossbar ..	14.25 in. (362 mm)

T82;CRSP AT 200285